

TEL-A-GREETER 252

Installation & Operation Manual

Please leave this manual with the unit after installation

Table of Contents

Introduction		
System Description	3	
Sample Applications	4	
Installation		
General Information	5	
Standard Installation	5	
KSU / PBX Installation	6	
Installation Notes	7	
Lights & Indicators		
Mode Light	8	
Line Lights	8	
Set up / Operation		
Factory Reset	9	
Seizing Control	9	
Modes of Operation	9	
Set Message Configuration	10	
Message Delete	11	
Message Record	11	
Message Review	12	
Mode Request	12	
Mode Set	12	
Set Rings	13	
Set Repeats	13	
Set Transfer Option	13	
Set Transfer Wait Time	14	
Activate Screening	14	
Set Screen Password	14	
Set Master Password	14	
Memory Request	15	
Memory Test	15	
Restore Defaults	15	
APPENDIX A – Troubleshooting		16
APPENDIX B - Message Configuration Tables	17	
APPENDIX C - Command Summary	19	
APPENDIX D - Default Settings	20	
APPENDIX E - Sample Application Details	21	
APPENDIX F - Specifications	22	
APPENDIX G - Contacting Nel-Tech Customer Support	23	
APPENDIX H - Notices & Warranty	23	

INTRODUCTION

SYSTEM DESCRIPTION

The Tel-A-Greeter 252 (TAG) is an advanced digital call screening and messaging system designed to answer calls with an informative greeting, then let the callers ring through for live pick up, select another pre-recorded message, or hang up.

The TAG 252 is a two line unit capable of handling two calls simultaneously.

Message recording and system programming functions are accessed locally or remotely by a standard touch-tone phone.

Additional standard system features include:

- Separate Day and Night message
- Hold message which plays while the Tel-A-Greeter is transferring a call
- Up to 8 Auxiliary messages from which callers can choose
- Call screening option, with pass code ring through
- Bypass mode, calls ring directly through to the switchboard

TAG Messaging Flow

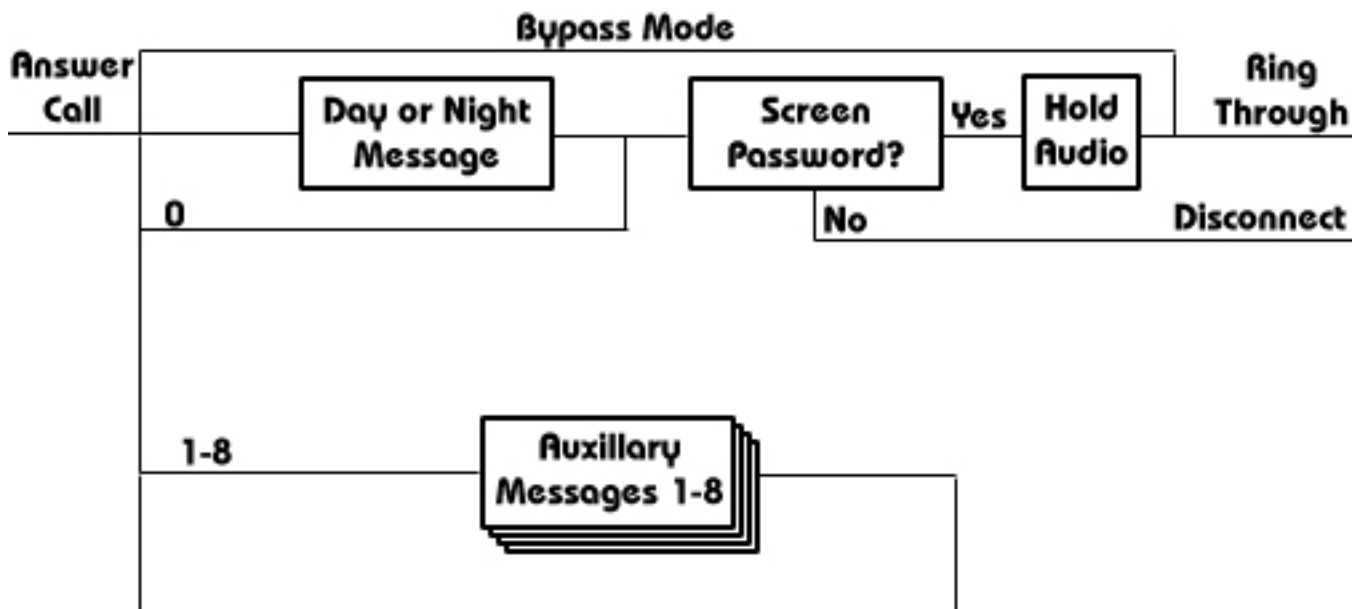

SAMPLE APPLICATIONS

Typical TAG applications are come in two basic categories, answer announce only and answer announce with ring through. Answer announce only applications allow the caller to get some information, but does not let them ring through to the switchboard. Answer announce with ring through allows the caller to get information and then either automatically or on pressing "0" get transferred to the switchboard. The TAG features two messaging modes, one for day and one for night, each of which can be set up separately to support either type of application.

Some example applications follow:

The Bank

- | | |
|-----------------|---|
| Day Message For | Hello and thank you for calling. If you are calling for our hours please press 1. today's interest rate press 2. Or stay on the line and one of our representatives will be with you as soon as possible. |
| Night Message | Hello and thank you for calling, unfortunately we are not open at this time. Our office hours are from 9am to 4:30pm Monday through Friday. |
| Aux. Message #1 | Our office hours are from 9am to 4:30pm Monday through Friday. |
| Aux. Message #2 | Today's interest rate is 6.5%. |

At the bank each morning, the staff records a new Aux. Message #2 with the current rate and then places the unit in day mode. Through the day the TAG answers the line and plays the Day Message and Aux. Message #1 or #2 as requested, allowing callers to ring through to the bank staff if needed. At the end of the day the staff places the TAG into Night mode. Night mode is set to play the Night Message and then hang up on the caller, preventing the staff from being bothered by unwanted calls.

The Real-Estate Agent

- | | |
|-----------------|--|
| Day Message | Hello and thank you for calling. I am out of the office right now but have a number of listings to tell you about. For information on a beautiful colonial on a large lot press 1. For information on a spacious 4 bedroom press 2. For information on a duplex that's a great investment press 3. Thank you and have a great day. |
| Aux. Message #1 | This beautiful colonial sits on a large lot over looking the river..... |
| Aux. Message #2 | This spacious 4 bedroom has two full baths, attached garage..... |
| Aux. Message #3 | This great investment property features..... |

As houses go on and off the market, the Real-estate Agent updates the Day Message, and any other messages that need to be changed. When ever the Agent goes out on a call, or home for the day, he/she places the unit in Day Mode, playing the Day Message and any requested Aux. Messages, then hanging up. While in the office the Agent places the unit in Bypass Mode, where all calls ring straight through to the switchboard as if the TAG were not present.

See Appendix C for programming details for these sample applications.

INSTALLATION

GENERAL INFORMATION

Situate the TAG in close proximity to the telephone line which the unit is to answer and within 6' of a 110VAC wall outlet. The TAG is designed to mount on a wall, shelf or other flat surface. When mounting the unit, be sure to leave clearance at the rear of the unit for connection accessibility.

STANDARD INSTALLATION

Install the TAG directly on the incoming telephone line at a point before the line is split into multiple extension lines. If you fail to do so, all of the extension phones ring each incoming call and only calls received by the unit are transferred to the phone attached directly to the unit. If you cannot locate the point at which your telephone line is split into extensions or if you are unable to tap into the line at this point, contact your telephone company.

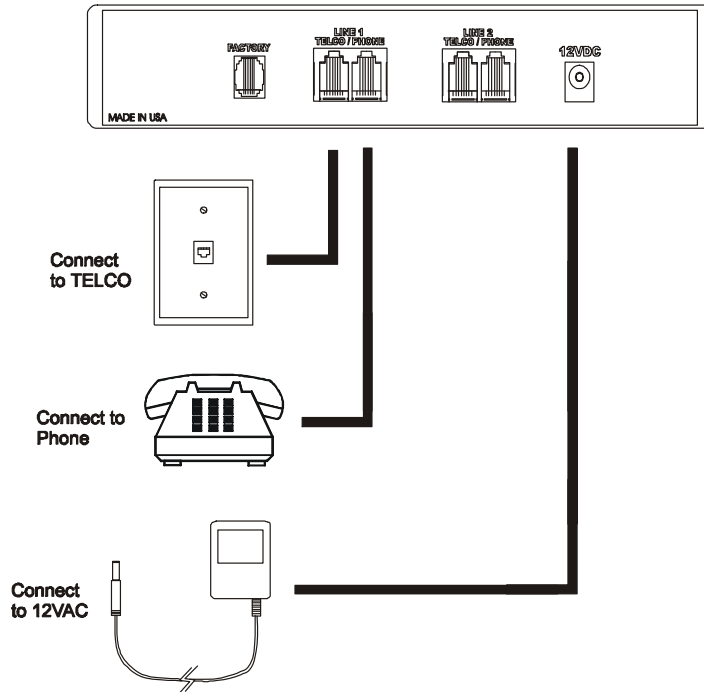

Follow steps 1-6 for standard installation:

1. Attach one end of the included modular telephone cable to the TELCO jack of the TAG.
2. Attach the other end of the included modular telephone cable to the wall jack of the line intended for use.
3. Connect one end of a modular telephone cable to the PHONE jack of the TAG.
4. Connect the other end of the modular telephone cable to the telephone intended for use.

NOTE: Repeat steps 1-4 for the two line TAG 252

5. Attach the included power supply to the 12VAC jack of the TAG.
6. Plug the other end of the power supply into the 110VAC wall outlet.

NOTE: Applying power to the TAG disrupts any calls in progress on the installed lines

KSU / PBX INSTALLATION

The TAG must be installed on the phone company side of your phone system. If installed directly to an unsuitable extension line the phone system or the TAG may be damaged. If you are not familiar with how your phone system is installed, or do not know which lines go directly to your phone company please find a qualified person to perform the installation.

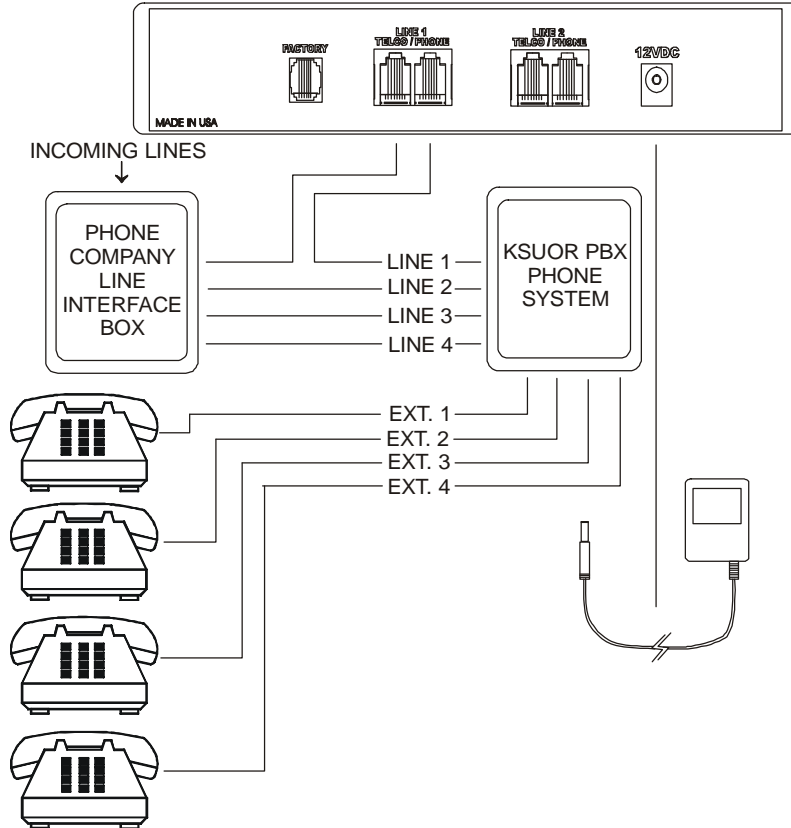

Follow steps 1-4 for KSU/PBX installation:

1. From your telephone system input, disconnect the telephone line for which the TAG is to answer.
2. Attach the disconnected line to the TELCO jack of the TAG.
3. Connect one end of the included modular telephone cable to the PHONE connector of the TAG.
4. Connect the other end of the modular telephone cable to the input of your phone system, where you made the original disconnection.

NOTE: Repeat steps 1-4 for the two line TAG 252

5. Attach the included power supply to the 12VAC jack of the TAG.
6. Plug the other end of the power supply into the 110VAC wall outlet.

NOTE: Applying power to the TAG disrupts any calls in progress on the installed lines

INSTALLATION NOTES

Required Lines

The TAG does not require phones to be attached to the PHONE connectors for operation. The TAG does require a working phone line to be attached to the TELCO connector in order to seize control from the associated PHONE connector.

Hunt Groups

Hunt groups are a set of lines that all answer to the same number, if the first number in the group is busy the next call rings in on the next line in the set and so on. This service is arranged through the phone company. If installing the TAG on lines arranged in a hunt group, be sure to place the unit on the first, or first two (TAG 252) incoming lines. Be aware that the TAG can only handle one (TAG 251) or two (TAG 252) calls simultaneously. If placed in a hunt group with more lines additional calls bypass the TAG and ring straight through.

RJ-11 Wiring

The TAG uses only the inner pair of conductors on its RJ-11 jacks, and does not pass the outer pair between the Telco and Phone jacks.

Hook Flash Transfers

Some installations may use services such as CENTREX or CALL WAITING that rely on a Hook Flash signal being sent to the Central Office. The TAG is not compatible with these services and interferes with the Hook Flash signal.

CPC

The TAG is designed to use the Calling Party Control signal sent from the Central Office to sense when the caller has hung up the phone. Not all Central Offices support CPC signaling. If the TAG does not receive the CPC signal it may take as long as 90 seconds after message play is complete to return to normal operation and calls also ring through even if the calling party has hung up during the message or transfer.

REN

The TAG supports an outgoing Ringer Equivalence Number of 5. To identify the REN requirements of your installation look for the REN number listed on each device question installed on line after the TAG. Add these values together and confirm that the total is less than 5.

LIGHTS & INDICATORS

The TAG front panel has a multi-colored Mode LED and a green Line LED for each available line.

MODE LED

The Mode LED normally flashes green to indicate the answer mode that the unit is currently operating in:

- 1 Flash = Day Mode
- 2 Flashes = Night Mode
- 3 Flashes = Bypass Mode

The Mode LED also flashes amber as the TAG processes commands.

In the event of a system failure, the mode LED flashes red.

LINE LEDs

The Line LEDs light green whenever the TAG is in control of the line in command mode.

SET UP / OPERATION

FACTORY RESET

The TAG can be reset to the factory default settings by holding the mode button down while power is applied. This brings the system to a known state which provides a good starting point for system configuration. See Appendix D for a full listing of the default values.

SEIZING CONTROL

The TAG is setup by seizing control of the unit by entering the Command Mode and then entering a series of two digit command codes to manipulate settings and record messages. Seizing control of a unit can be done by one of two ways:

- **Local** - Through the use of a phone that is installed on the same line as the TAG. Control is seized by picking up the handset of the local phone, listening for a dial tone and then entering # * * followed by the Master Password (factory default = "1 2 3 4"). After entering # * * followed by the Master Password, the dial tone may change to a busy tone or start ringing, ignore it. Within 5 seconds of entering the Master Password the TAG seizes the line and plays a triple beep indicating it has been placed in Command Mode.
- **Remote** - Through the use of a phone that is not installed on the same line as the TAG. Control is seized by placing a call to the line which the TAG is installed. The TAG has several modes of operation and how the line is remotely seized differs between modes:

Bypass Mode (factory default) - The unit answers and beeps once after a predetermined number of rings(factory default = 15). As soon as the rings expire and the unit picks up the line, proceed by entering # * * followed by the Master Password (factory default = "1 2 3 4"). Within 5 seconds of entering the Master Password the TAG seizes the line and plays a triple beep indicating it has been placed in Command Mode. Failure to enter a password within 20 seconds of the unit answering results in disconnection.

Day / Night Mode - The unit answers and plays the message after a predetermined number of rings(factory default = 1). As soon as message play begins you may proceed by entering # * * followed by the Master Password (factory default = "1 2 3 4"). Within 5 seconds of entering the Master Password the TAG seizes the line and plays a triple beep indicating it has been placed in Command Mode. Failure to enter a password after the end of the message results in disconnection.

NOTE: When control has been seized from the Remote, a busy signal is heard on the Local side.

Once the unit is in Command Mode the user may start entering commands. All commands start by entering "*" and end by entering a "#". After each valid command, a single success beep sounds, invalid entries are indicated by an double beep error tone.

NOTE: On a TAG 252, seizing control causes any calls in progress on the other line to be disconnected.

MODES OF OPERATION

The TAG is operated in one of three answer modes:

Bypass Mode

The TAG defaults to Bypass Mode when there are no messages present. Calls come in and ring directly through to the switchboard as if the TAG was not in place at all. The only way that the TAG responds in Bypass Mode is by answering the line on a specific number of rings(factory Default = 03) set by the Bypass Rings command so that the Master Password can be entered to seize control of the unit.

Day / Night Mode

Day and Night Mode consist of identical features and functions, allowing for two separate messages that are uniquely programmed.

- **Day Mode** - By default the TAG answers the line on the first ring and proceeds to play the Day message then transfers the call to the switchboard..
- **Night Mode** - By default the TAG answers the line on the first ring and proceeds to play the Night message then hangs up.

During message play, the caller also has the option to enter "1-8" and listen to the corresponding auxiliary message or entering the staff password to listen to the private message. If any message is selected during message play it is followed by a repeat of the primary message for that mode.

The Day and Night modes also have a number of settings that can further customize each mode for your application including Ring to Answer On, Number of Repeats, Call Screening, Transfer Option and Transfer Wait Time. See the specific section for further information on each of these settings.

SET MESSAGE CONFIGURATION

The Message Configuration is represented by a four digit code. Reference the following configuration breakdown or the **MESSAGE CONFIGURATION TABLES** in Appendix B to determine the valid code that represents your messaging needs.

The first digit specifies the basic message configuration:

- 1XXX = Day Message
- 2XXX = Day and Night Message
- 3XXX = Day, Night, and Hold Message

The second digit specifies the number of auxiliary messages allocated:

- X0XX = No auxiliary messages
- X2XX = 2 auxiliary messages
- X4XX = 4 auxiliary messages
- X8XX = 8 auxiliary messages

The third and fourth digit specifies the combined minutes of memory allocated for the auxiliary messages

- | | |
|------------------------------|-------------------|
| XX00 = No auxiliary messages | XX08 = 8 minutes |
| XX02 = 2 minutes | XX10 = 10 minutes |
| XX04 = 4 minutes | XX12 = 12 minutes |
| XX06 = 6 minutes | XX14 = 14 minutes |

If the Message Configuration command is valid the user hears the success beep and returns to command mode ready to enter the next command. If the entered code is not valid the user hears the error tone and returns to command mode ready to enter the next command.

Syntax... (X X X X = any value from the **MESSAGE CONFIGURATION TABLES** - Appendix B)

* 9 8 # X X X X # Set Message Configuration

NOTE: Changing the Message Table results in the loss of all previously recorded messages and sets the Answer Mode to Bypass.

MESSAGE DELETE

Each Message Delete command allows the user to delete one of the eleven messages. While the message is being deleted the user hears the system busy signal for a period of time followed by the success beep, returning to command mode ready to enter the next command. If the user deletes the primary message for the current Answer Mode, the unit reverts to Bypass Mode after the call is complete.

Syntax:

- * 7 0 # 0 1 # Delete Day Message
- * 7 0 # 0 2 # Delete Night Message
- * 7 0 # 0 3 # Delete Hold Message
- * 7 0 # 1 1 # Auxiliary #1 Message Delete
- * 7 0 # 1 2 # Auxiliary #2 Message Delete
- * 7 0 # 1 3 # Auxiliary #3 Message Delete
- * 7 0 # 1 4 # Auxiliary #4 Message Delete
- * 7 0 # 1 5 # Auxiliary #5 Message Delete
- * 7 0 # 1 6 # Auxiliary #6 Message Delete
- * 7 0 # 1 7 # Auxiliary #7 Message Delete
- * 7 0 # 1 8 # Auxiliary #8 Message Delete

MESSAGE RECORD

The Message Record commands allows the user to record one of the available messages. The available messages and message lengths vary with the Message Table and installed memory, see the Message Configuration command for more information. After the command is entered, the TAG plays a steady series of short beeps(ready tones) At any point after the ready tones begin, the user may enter " * " to start the recording. Recording continues until the user enters " # " or the maximum record time for the message is reached. At this point, the TAG plays a success beep and is ready to receive the next command . The error tone sounds if the user attempts to record a message that is not available in the current Message Table or if the selected message has previously been recorded and not erased.

Syntax:

- * 5 0 # 0 1 # Record Day Message
- * 5 0 # 0 2 # Record Night Message
- * 5 0 # 0 3 # Record Hold Message
- * 5 0 # 1 1 # Record Auxiliary #1 Message
- * 5 0 # 1 2 # Record Auxiliary #2 Message
- * 5 0 # 1 3 # Record Auxiliary #3 Message
- * 5 0 # 1 4 # Record Auxiliary #4 Message
- * 5 0 # 1 5 # Record Auxiliary #5 Message
- * 5 0 # 1 6 # Record Auxiliary #6 Message
- * 5 0 # 1 7 # Record Auxiliary #7 Message
- * 5 0 # 1 8 # Record Auxiliary #8 Message

MESSAGE REVIEW

The Message Review commands allows the user to review one of the eleven messages. After the command is entered the requested message plays. After message play completes the user hears the success beep and returns to command mode ready to enter the next command. The user may enter " # " at any point during message review to abort the play back, at which point the user hears the success beep and returns to command mode ready to enter the next command. If the selected message has not been recorded the user hears the error tone and returns to command mode ready to enter the next command.

Syntax:

- * 6 0 # 0 1 # Day Message Review
- * 6 0 # 0 2 # Night Message Review
- * 6 0 # 0 3 # Hold Message Review
- * 6 0 # 1 1 # Auxiliary #1 Message Review
- * 6 0 # 1 2 # Auxiliary #2 Message Review
- * 6 0 # 1 3 # Auxiliary #3 Message Review
- * 6 0 # 1 4 # Auxiliary #4 Message Review
- * 6 0 # 1 5 # Auxiliary #5 Message Review
- * 6 0 # 1 6 # Auxiliary #6 Message Review
- * 6 0 # 1 7 # Auxiliary #7 Message Review
- * 6 0 # 1 8 # Auxiliary #8 Message Review

MODE REQUEST

The Mode Request command responds with beep tones to indicate the answer mode that the unit is currently operating in:

- 1 Beep = Day Mode
- 2 Beeps = Night Mode
- 3 Beeps = Bypass Mode

After hearing the beeps the user returns to command mode ready to enter the next command.

Syntax:

- * 0 0 # Request current mode

MODE SET

The Mode Set command puts the unit into one of the three answer modes. A mode is only valid if it's primary message has been recorded. Day Mode's primary message is the Day Message and Night Mode's primary Message is the Night Message. Bypass Mode has no primary message and is always valid. If the selected mode is valid the user hears the number of success beeps that corresponds with the mode number set then returns to command mode ready to enter the next command. If the selected mode is not valid the user hears the error tone and then returns to command mode ready to enter the next command.

Syntax:

- * 0 1 # Set for Day Mode = 1 Beep
- * 0 2 # Set for Night Mode = 2 Beeps
- * 0 3 # Set for Bypass Mode = 3 Beeps

SET RING

Set Rings command sets the number of rings that the unit answers on in a particular answer mode. Valid numbers of rings for all modes range from 2 to 15. If a valid number of rings is entered the user hears the success beep and returns to command mode ready to enter the next command. If the entered number of rings is not valid the user hears the error tone and returns to command mode ready to enter the next command.

Answer on Ring	Day Mode Syntax	Night Mode Syntax	Bypass Mode Syntax
2	* 1 1 # 0 2 #	* 2 1 # 0 2 #	* 9 0 # 0 2 #
3	* 1 1 # 0 3 #	* 2 1 # 0 3 #	* 9 0 # 0 3 #
4	* 1 1 # 0 4 #	* 2 1 # 0 4 #	* 9 0 # 0 4 #
5	* 1 1 # 0 5 #	* 2 1 # 0 5 #	* 9 0 # 0 5 #
6	* 1 1 # 0 6 #	* 2 1 # 0 6 #	* 9 0 # 0 6 #
7	* 1 1 # 0 7 #	* 2 1 # 0 7 #	* 9 0 # 0 7 #
8	* 1 1 # 0 8 #	* 2 1 # 0 8 #	* 9 0 # 0 8 #
9	* 1 1 # 0 9 #	* 2 1 # 0 9 #	* 9 0 # 0 9 #
10	* 1 1 # 1 0 #	* 2 1 # 1 0 #	* 9 0 # 1 0 #
11	* 1 1 # 1 1 #	* 2 1 # 1 1 #	* 9 0 # 1 1 #
12	* 1 1 # 1 2 #	* 2 1 # 1 2 #	* 9 0 # 1 2 #
13	* 1 1 # 1 3 #	* 2 1 # 1 3 #	* 9 0 # 1 3 #
14	* 1 1 # 1 4 #	* 2 1 # 1 4 #	* 9 0 # 1 4 #
15	* 1 1 # 1 5 #	* 2 1 # 1 5 #	* 9 0 # 1 5 #

SET NUMBER OF REPEATS

The Set Number of Repeats command sets the number of times the primary message repeats in that answer mode. Valid numbers of repeats for both modes range from 00 to 15. If a user enters a valid number they hear the success beep and return to command mode ready to enter the next command. If the entered number is not valid the user hears the error tone and returns command mode ready to enter the next command.

Syntax... (X X = any value 00 - 15)

- * 1 6 # X X # Set Repeats for Day Mode
- * 2 6 # X X # Set Repeats for Night Mode

SET TRANSFER OPTION

Both Day and Night Modes may be independently set to transfer in any of the three options. Transfer Options are selected by number where valid numbers range from 01 to 03 as numbered below. If a user enters a valid number they hear the success beep and return to command mode ready to enter the next command. If the entered number is not valid the user hears the error tone and returns to command mode ready to enter the next command.

Command	Day Mode Syntax	Night Mode Syntax
Transfer call after message play or if caller enters "0"	* 1 2 # 0 1 #	* 2 2 # 0 1 #
Disconnect call after message play	* 1 2 # 0 2 #	* 2 2 # 0 2 #
Transfer call only when caller enters "0"	* 1 2 # 0 3 #	* 2 2 # 0 3 #

SET TRANSFER WAIT TIME

Transfer Wait times can be set independently for both Day and Night Modes. The user may set a period of time for the TAG to wait for input before disconnecting a caller when using Transfer Options 2(Disconnect) and 3(Transfer on Input). Transfer Wait Time can be set for any value from 01 to 30 seconds. If a user enters a valid value they hear the success beep and return to command mode ready to enter the next command. If the entered value is not valid the user hears the error tone and returns to command mode ready to enter the next command. This command has no effect on Transfer Option 1(Transfer Always).

Syntax... (X X = any value 01 - 30)

- * 1 5 # X X # Set Wait Time for Day Mode
- * 2 5 # X X # Set Wait Time for Night Mode

ACTIVATE SCREENING

Call screening can be activated independently for both Day and Night Modes. Call Screening allows the caller to enter a special password that forces a transfer to the switchboard in any transfer mode. This feature allows the user to use Transfer Option 2(Disconnect) yet still receive critical or personal calls on the line. Entering a 01 activates Call Screening for that mode while a 02 de-activates it. 01 and 02 are the only valid numbers for this command. If a user enters a valid number they hear the success beep and return to command mode ready to enter the next command. If the entered number is not valid the user hears the error tone and returns to command mode ready to enter the next command.

Command	Day Mode Syntax	Night Mode Syntax
Set Call Screening On	* 1 3 # 0 1 #	* 2 3 # 0 1 #
Set Call Screening Off	* 1 3 # 0 2 #	* 2 3 # 0 2 #

SET SCREEN PASSWORD

The Set Screen Password command changes the units Screen Password. The Screen Password allows access to the switch board if Call Screening is active for that Answer Mode. If the Set Screen Password command is entered correctly the user hears the success beep and returns to command mode ready to enter the next command. To use the screening feature the caller must enter 0 during message play then X X X X after the beep where X X X X is the Screen Password.

Syntax... (X X X X = any value 0000 - 9999)

- * 9 4 # X X X X # Set Screen Password

SET MASTER PASSWORD

The Set Master Password command changes the units Master Password. Changing the Master Password prevents unauthorized access to command mode. If the Set Master Password command is entered correctly the user hears the success beep and returns to command mode ready to enter the next command. If the entered password is not valid the user hears the error tone and returns command mode ready to enter the next command.

Syntax... (X X X X = any value 0000 - 9999)

- * 9 2 # X X X X # Set Master Password

NOTE: If you forget or lose your Master Password you will be unable to seize control of your unit, either remotely or locally, until the unit is reset on power.

MEMORY REQUEST

The Memory Request command allows the user to identify how much memory is installed in the system. If the command is correctly entered the user hears several beeps where each beep represents 1 installed memory chip, or 2 MB of memory. After the command has completed the unit returns to command mode ready to enter the next command.

Syntax...

* 8 0 # Memory Request

MEMORY TEST

The Memory Test command performs a diagnostic on the audio memory, testing for errors. If the command is correctly entered the user hears the system busy signal for a period of time while the test is performed, followed by the success beep or error tone depending on the outcome of the test. After the command has completed the unit returns to command mode ready to enter the next command.

Syntax...

* 8 1 # Memory Test

NOTE: The Memory Test command erases all messages and resets the unit to the factory default settings.

RESTORE DEFAULT CONFIGURATION

The Restore Default Configuration command restores the unit to the factory defaults. This command brings the system to a known state which provides a good starting point for system configuration. If the command is correctly entered the user hears the system busy signal for a period of time while the units memory is erased, followed by the success beep, returning to command mode ready to enter the next command. See Appendix D for a full listing of the default values.

Syntax...

* 9 9 # Restore default configuration

APPENDIX A

Troubleshooting

Problem or Indication	Possible Cause and Solution
What do the lights mean?	<ul style="list-style-type: none"> ▪ 1 Blink – Day Mode ▪ 2 Blinks – Night Mode ▪ 3 Blinks – Bypass Mode
Why can't I record a message?	Make sure that you are in Command Mode, and that the message slot you are trying to fill is blank.
I recorded a message but when I call it, it doesn't play.	Make sure the unit has been put into Day or Night Mode.
I can't get the unit to go into Day or Night Mode.	A Day or Night message must be present in order to activate the Day or Night Mode.
I enter #**1234 to get into Command Mode and nothing happens or I get the operator.	The TAG can't be controlled through a PBX or KSU. You must plug a standard analog phone into the phone port to access Command Mode locally, or call into the unit on a different line.
I press *50#01# to record the greeting message and my message doesn't get recorded.	You must press * after entering in the record command syntax and then # to end the recording.
When I pick up a line plugged into the TAG, to make a call, I hear beeping tones.	Someone has called in, and the line is in use by the TAG.
After the message plays I hear beeping tones and then the unit hangs up.	The TAG is ringing the line plugged into it's phone port. Each beep represents a normal ring tone since the TAG has a tone generator not a ring generator.

APPENDIX B

MESSAGE CONFIGURATION TABLES

The following tables show the message lengths for each of the valid Message Configurations, based on the amount of installed memory.

8 Minute Message Table

Code	Day	Night	Hold	Aux #1	Aux #2	Aux #3	Aux #4	Aux #5	Aux #6	Aux #7	Aux #8
1000	480										
2000	240	240									
3000	150	150	150								
1202	360			60	60						
1402	360			30	30	30	30				
1802	360			15	15	15	15	15	15	15	15
2202	180	180		60	60						
2402	180	180		30	30	30	30				
2802	180	180		15	15	15	15	15	15	15	15
3202	120	120	120	60	60						
3402	120	120	120	30	30	30	30				
3802	120	120	120	15	15	15	15	15	15	15	15
1204	240			120	120						
1404	240			60	60	60	60				
1804	240			30	30	30	30	30	30	30	30
2204	120	120		120	120						
2404	120	120		60	60	60	60				
2804	120	120		30	30	30	30	30	30	30	30
3204	80	80	80	120	120						
3404	80	80	80	60	60	60	60				
3804	80	80	80	30	30	30	30	30	30	30	30
1206	120			180	180						
1406	120			90	90	90	90				
1806	120			45	45	45	45	45	45	45	45
2206	60	60		180	180						
2406	60	60		90	90	90	90				
2806	60	60		45	45	45	45	45	45	45	45
3206	30	30	30	180	180						
3406	30	30	30	90	90	90	90				
3806	30	30	30	45	45	45	45	45	45	45	45

APPENDIX C

COMMAND SUMMARY

NAME	SYNTAX	RANGE	DESCRIPTION
Mode Request	* 0 0 #	None	Beeps 1 to 3 times to indicate Answer Mode
Day Set	* 0 1 #	None	Sets Answer Mode to Day
Night Set	* 0 2 #	None	Sets Answer Mode to Night
Bypass Set	* 0 3 #	None	Sets Answer Mode to Bypass
Day Rings	* 1 1 # X X #	02 - 15	Sets ring to answer on in Day Mode
Day Option	* 1 2 # X X #	01 - 03	Sets Transfer Option in Day Mode
Day Screen	* 1 3 # X X #	01 - 02	Sets Day Mode Screening On(01) / Off(02)
Day Wait	* 1 5 # X X #	01 - 30	Sets wait time for input in Day Mode
Day Repeats	* 1 6 # X X #	00 - 15	Sets number of Day Message repeats
Night Rings	* 2 1 # X X #	02 - 15	Sets ring to answer on in Night Mode
Night Option	* 2 2 # X X #	01 - 03	Sets Transfer Option in Night Mode
Night Screen	* 2 3 # X X #	01 - 02	Sets Night Mode Screening On(01) / Off(02)
Night Wait	* 2 5 # X X #	01 - 30	Sets wait time for input in Night Mode
Night Repeats	* 2 6 # X X #	00 - 15	Sets number of Night Message repeats
Message Record	* 5 0 # X X #	None	Records Messages 01= Day, 02= Night, 03= Hold, 11-18= Aux
Message Review	* 6 0 # X X #	None	Reviews Messages 01= Day, 02= Night, 03= Hold, 11-18= Aux
Message Delete	* 7 0 # X X #	None	Deletes Messages 01= Day, 02= Night, 03= Hold, 11-18= Aux
Bypass Rings	* 9 0 # X X #	02 - 15	Sets the Maximum number of Rings
Master Password	* 9 2 # X X X X #	0000 - 9999	Sets the Master Password
Screen Password	* 9 4 # X X X X #	0000 - 9999	Sets the Screen Password
Message Table	* 9 8 # X X X X #	1000 - 3814	Selects a Message Table
Reset	* 9 9 #	None	Resets Unit to default settings

APPENDIX D

DEFAULT SETTINGS

This table lists the settings that your unit has when first powered up or after using the Restore Default Configuration command(99).

Answer Mode	03 (Bypass)
Message Table	3802 (Day, Night, Hold and 8 Auxiliary Messages)
Day Rings	02
Day Option	01 (Transfer)
Day Transfer Wait Time	10
Day Repeats	0
Bypass Rings	03
Night Rings	02
Night Option	02 (Disconnect)
Night Screen	02 (Off)
Night Transfer Wait Time	1010
Night Repeats	0
Master Password	1234
Screen Password	2468

APPENDIX E

SAMPLE APPLICATION DETAILS

The Bank

The Bank application uses a Day, a Night and two short Auxiliary messages so the best Memory Configuration would probably be 2202

2	2 Main Messages - Day, Night
2	2 Aux.Messages - Office Hours, Interest Rates
0	02 Minutes of Aux. Message time split between the 2 Aux. Messages
2	

The Day Mode and Night Mode operation are fairly standard so the default values for the Day and Night settings could be used

Rings	Ring to Answer On - Day = 1, Night = 1
Transfer Option	Action after Message completes - Day = 1(Transfer), Night = 2(Hang up)
Screen	Screening in Transfer Option 2(Hang up) - Day = 1(On), Night = 1(On)
Transfer Wait	Time before hang up in Transfer Option 2 & 3 - Day = 10, Night = 10
Repeats	Number of times message will repeat - Day = 0, Night = 0

The Real-estate Agent

The Real-estate Agent application uses a Day and up to eight long Auxiliary messages so the best Memory Configuration would probably be 1806 for a eight minute unit or 1814 for a sixteen minute unit.

1	1 Main Messages - Day
8	8 Aux.Messages - House Listings
X	(06 Mins. of Aux. Message time split between the 8 Aux. Msgs. for a eight minute unit)
X	(14 Mins. of Aux. Message time split between the 8 Aux. Msgs. for a sixteen minute unit)

The Day Mode is being used but the application calls for the caller not to ring through so the Day Transfer Option must be changed to 02(Disconnect). The remaining Day Settings can be left at the defaults.

Rings	Ring to Answer On - Day = 1, Night = 1
Transfer Option	Action after Message completes - Day = 2(Hang up), Night = 2(Hang up)
Transfer Wait	Time before hang up in Transfer Option 2 & 3 - Day = 10, Night = 10
Repeats	Number of times message will repeat - Day = 0, Night = 0

APPENDIX F

SPECIFICATIONS

AUDIO

Encoding/Decoding	8 Bit U-LAW
Sampling Frequency	8Khz
Frequency Response	50 Hz to 3.5 kHz +/- 1.5 db

MEMORY

Type	Flash
Size	4 or 8 Megabytes

MESSAGING

Number of Messages	11 variable length
Total Message Time	8 or 16 minutes

CONNECTORS

Power	2.5mm Power Connector
Line 1 Telco	RJ-11 Type Modular Jack
Line 1 Phone	RJ-11 Type Modular Jack
Line 2 Telco	RJ-11 Type Modular Jack
Line 2 Phone	RJ-11 Type Modular Jack
Factory	RJ-45 Type Modular Jack

TELCO INTERFACE

REN(in)	1.2b
REN(out)	5b
Ringer Output	60V(RMS), 20 Hz
Required Line	90V Ring, Loop Start

POWER

Primary Input	12VAC @ 850mA
Source	110VAC, 60 Hz UL/CSA Listed Power Pack

APPENDIX G

CONTACTING NEL-TECH CUSTOMER SUPPORT

Only contact customer service if you are unable to resolve your problem through the dealer you purchased from, and while you are able to review and make changes to the settings on the TAG you are experiencing problems with.

NOTE: Nel-Tech customer service provides support for the TAG only. If you are experiencing problems with your phone system itself please refer your problem to the correct vendor.

Customer service can be reached Monday through Friday at 603-425-1096, from 8:00 to 5:00 EST.

APPENDIX H

NOTICES & WARRANTY

FCC Notice

WARNING: This equipment HAS BEEN TESTED AND FOUND TO COMPLY WITH THE LIMITS FOR A CLASS A DIGITAL DEVICE PURSUANT TO PART 15 OF FCC RULES. THESE LIMITS ARE DESIGNED TO PROVIDE REASONABLE PROTECTION AGAINST HARMFUL INTERFERENCE WHEN THIS EQUIPMENT IS OPERATED IN A COMMERCIAL ENVIRONMENT. This equipment generates, uses, and can radiate radio frequency energy and, if not installed and used in accordance with the instruction manual, may cause harmful interference to radio communications. Operation of this equipment in a residential environment is likely to cause harmful interference in which case the user will be required to correct the interference AT HIS/HER OWN EXPENSE.

LIMITED WARRANTY

NTL warrants that all equipment sold is free from defects in material and workmanship at the time of purchase. The warranty extends 5 years from the date of original purchase and covers parts and labor. Buyer must provide written notice to NTL within the warranty period of any defective part or conditions. If the defect is not the result of improper use, service, maintenance or installation, and if the equipment has not been otherwise damaged or modified after shipment, NTL or its authorized representative shall either replace or repair the defective equipment at NTL's option. After return of such equipment by buyer to NTL, or its representative, shipment shall be paid for by buyer. No credit shall be allowed for work performed by the buyer. Out-of-warranty repairs will be invoiced at the current NTL hourly rate plus the cost of parts, and shipping.

All implied warranties, if any, terminate three years from date of original purchase. NTL is not responsible for damage to other equipment or property or any other consequential incidental damage of any kind, whether based upon contract, negligence or strict liability. Maximum liability shall not, in any case, exceed the purchase price of the equipment.

The foregoing constitutes NTL's entire obligation with respect to this product. The original purchaser and user or owner shall have no other remedy and no claim for incidental or consequential damages. Some states do not allow limitations of how long an implied warranty lasts or do not allow the exclusion of incidental or consequential damages, therefore, the above limitations and exclusions may not apply to you.

This warranty gives specific legal rights. You may also have other rights which vary from state to state.

COPYRIGHT NOTICE

This manual is copyrighted. All rights reserved. This document may not, in whole or part, be copied, reproduced, reduced or translated by any means, either mechanical or electronic, without prior consent in writing from Nel-Tech Labs, Incorporated. The information in this manual has been carefully checked and is believed to be accurate. However, Nel-Tech Labs assumes no responsibility for any inaccuracies that may be contained in this manual. In no event will Nel-Tech Labs be liable for direct, indirect, special, incidental, or consequential damages resulting from any defect or omission in this manual, even if advised of the possibility of such damages.

In the interest of continued product development, Nel-Tech Labs reserves the right to make changes and improvements in this manual and the products it describes at any time, without notice or obligation.

Copyright © 1984 -2008 by Nel-Tech Labs, Inc.
4 Ash Street Extension, Derry NH, 03038

